

**Exhaust System - V8 5.0L Petrol/V8 S/C 5.0L Petrol -****Torque Specifications**

<b>Description</b>	<b>Nm</b>	<b>lb-ft</b>	<b>lb-in</b>
Catalytic converter retaining bolts	40	30	-
Rear muffler support retaining bolts	25	18	-
Exhaust securing strap nuts	55	40	-
Exhaust support retaining bolts	25	18	-

# Exhaust System - V8 5.0L Petrol/V8 S/C 5.0L Petrol - Exhaust System - Component Location

Description and Operation

COMPONENT LOCATION - 5.0L V8 SUPERCHARGER - FROM 2010MY - UP TO 2013MY

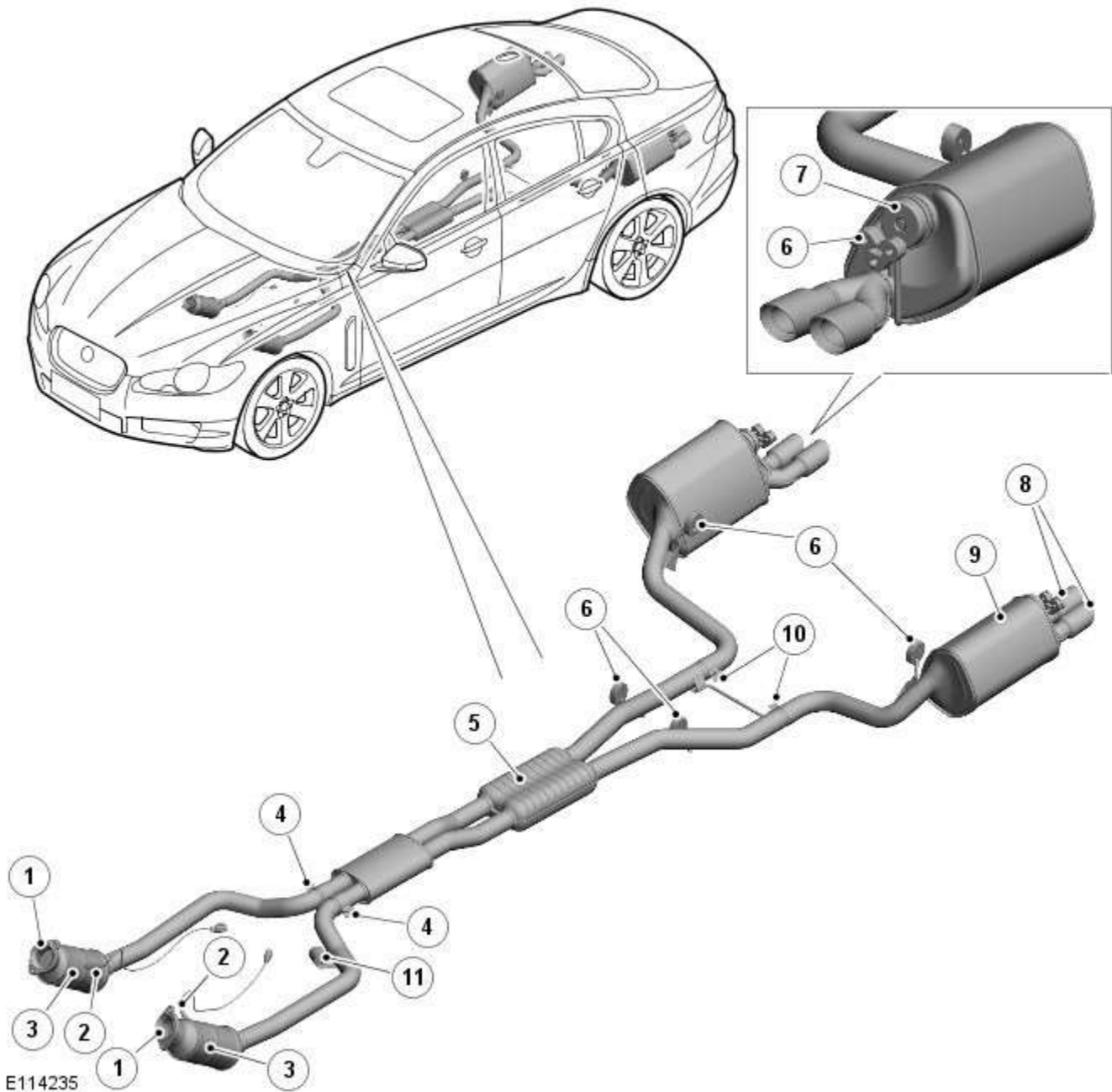

Item	Description
1	Manifold flange (2 off)
2	Mid catalyst <a href="#">HO2S</a> (2 off)
3	Catalytic converter (2 off)
4	Clamp (2 off)
5	Center resonator silencer (2 off)
6	Mounting rubber (6 off)
7	Semi-active muffler valve
8	Exhaust trim (2 off)
9	Rear silencer (2 off)
10	Clamp (2 off)
11	Mass damper

# Exhaust System - V8 5.0L Petrol/V8 S/C 5.0L Petrol - Exhaust System -

## Overview

Description and Operation

### OVERVIEW

#### 5.0L V8 NATURALLY ASPIRATED AND SUPERCHARGER - FROM 2010MY

The exhaust system fitted to models with the 5.0L V8 engines are fabricated from stainless steel. 5 separate assemblies make up the complete system.

The front section comprises 2 separate assemblies ([LH \(left-hand\)](#) and [RH \(right-hand\)](#)) incorporating a catalytic converter for each bank of cylinders. The rear section comprises 3 separate sections; a center section and two rear sections. The center section assembly incorporates a rear silencer which is connected to a center resonator silencer. On supercharger models, the center resonator is a one piece assembly with two inlet pipes from the center silencer and two outlet pipes to the rear silencers. On naturally aspirated models, each outlet pipe from the center silencer connects into an individual center resonator.

The system is attached to the underside of the body with mounting rubbers which are located on steel hanger bars that are welded to the system. The mounting rubbers locate on corresponding hangers which are welded or bolted to the underside of the vehicle body.

# Exhaust System - V8 5.0L Petrol/V8 S/C 5.0L Petrol - Exhaust System - System Operation and Component Description

Description and Operation

## System Operation

### CATALYTIC CONVERTERS

In the catalytic converters, the exhaust gases are passed through honeycombed ceramic elements coated with a special surface treatment called 'washcoat'. The washcoat increases the surface area of the ceramic elements by a factor of approximately 7000. On top of the washcoat is a coating containing palladium and rhodium, which are the active constituents for converting harmful emissions into inert by-products. The palladium and rhodium add oxygen to the carbon monoxide and the hydrocarbons in the exhaust gases, to convert them into carbon dioxide and water respectively.

### SEMI-ACTIVE MUFFLER VALVE (5.0L SUPERCHARGER VEHICLES ONLY)

The semi-active muffler valve is operated by the pressure in the exhaust system. At low engine speeds the valve head is closed or partially closed to provide a more refined noise quality. At higher engine speeds the increased pressure within the exhaust system opens the valve head to provide a more sporting noise. This is achieved by the valve, which once open, allows the exhaust gasses to by-pass the baffle tubes and plates in the rear silencer.

## Component Description

### FRONT SECTION - 4.2L NATURALLY ASPIRATED (NAS ONLY) - From 2010MY

The front section comprises two separate pipes, each incorporating a catalytic converter. Each catalytic converter has a welded inlet pipe with a flange. The inlet pipe is flared into a cone which mates with the exhaust manifold. The flange has two holes which locate on studs in the exhaust manifold and is secured with flanged nuts. Each catalytic converter is fitted with a pre and post catalyst [HO2S \(heated oxygen sensor\)](#).

Each catalytic converter has a curved outlet pipe which mates with the respective inlet pipe for the applicable resonator on the center section. The joint on each pipe is secured with a clamp.

### FRONT SECTION - 5.0L NATURALLY ASPIRATED AND SUPERCHARGER - From 2010MY

The front section is common to both the naturally aspirated and supercharger vehicles. The front section comprises two separate pipes each incorporating a catalytic converter. Each catalytic converter has a welded pipe with a flange, which is flared into a cone which mates with the exhaust manifold. Each flange has two holes which locate on studs in the exhaust manifold and are secured with nuts. Each catalytic converter is fitted with a mid catalyst [HO2S](#). The mid catalyst [HO2S](#) is located in the catalytic converter.



**NOTE:** The pre catalyst [HO2S](#) is located in the exhaust manifold.

On vehicles from 2013MY, a post catalyst [HO2S](#) is located in the curved pipe from each catalytic converter.

A curved pipe from each catalytic converter locates into the resonator inlet pipes of the center section. The [LH \(left-hand\)](#) pipe is fitted with a mass damper which absorbs resonance from the system.

### REAR SECTION - 4.2L NATURALLY ASPIRATED (NAS ONLY) - From 2010MY

The 2 inlet pipes each connect into a separate resonator silencer. Each resonator silencer is cylindrical in shape and houses 2 perforated tubes separated by 2 baffle plates. Exhaust gasses exit each resonator silencer via an outlet pipe. The 2 outlet pipes are joined together behind the resonators with a cross over pipe. Each pipe also has a welded hanger bracket which allow the rear section to be supported on mounting rubbers. A further bracket is welded to each pipe which braces the 2 pipes together.

The 2 rear silencers each have a welded inlet pipe which mate with the outlet pipes from the resonator silencers and are each secured with a clamp. The inlet pipes each have a welded hanger bracket which support each rear silencer at the rear of the vehicle on mounting rubbers. The fabricated rear silencers have 2 perforated tubes which are supported on 2 perforated baffle plates. The exhaust gasses are expelled from the rear silencer via a single outlet pipe. The outlet pipe from each silencer has a welded hanger bar which support the rear silencer on mounting rubbers. The outlet pipe is fitted with a welded outlet which is covered with a polished stainless steel finisher which is part welded to the silencer.

### REAR SECTION - 5.0L NATURALLY ASPIRATED - From 2010MY

The 2 pipes from the front section each connect into 2 short pipes on the center resonator box and are secured with clamps. Two pipes from the resonator box split the system into 2 sections which each connect into another resonator. Each resonator silencer houses perforated tubes separated by baffle plates. Exhaust gasses exit each resonator silencer via an outlet pipe. The 2 outlet pipes are joined together behind the resonators with a cross over pipe. Each pipe also has a welded hanger bracket which allow the rear section to be supported on mounting rubbers. A further bracket is welded to each pipe which braces the 2 pipes together.

The 2 rear silencers each have a welded inlet pipe which mate with the outlet pipes from the cylindrical resonator silencers and

are each secured with a clamp. The inlet pipes each have a welded hanger bracket which support each rear silencer at the rear of the vehicle on mounting rubbers. The fabricated rear silencers have 2 perforated tubes which are supported on 2 perforated baffle plates. The exhaust gasses are expelled from the rear silencer via a single outlet pipe. The outlet pipe from each silencer has a welded hanger bar which support the rear silencer on mounting rubbers. The outlet pipe is fitted with a welded outlet which is covered with a polished stainless steel finisher which is part welded to the silencer.

## REAR SECTION - 5.0L SUPERCHARGER - From 2010MY

The 2 pipes from the front section each connect into 2 short pipes on the center resonator box and are secured with clamps. Two pipes from the center resonator box each connect into a second resonator silencer. The resonator silencer comprises perforated tubes separated by 2 baffle plates. Exhaust gasses exit the resonator silencer via 2 outlet pipes. Each pipe has a welded hanger bracket which allows the rear section to be supported on mounting rubbers. A further bracket is welded to each pipe which braces the 2 pipes together.

The 2 rear silencers each have a welded inlet pipe which mate with the outlet pipes from the cylindrical resonator silencers and are each secured with a clamp. The inlet pipes each have a welded hanger bracket which support each rear silencer at the rear of the vehicle on mounting rubbers. The fabricated rear silencers have a perforated inlet tube which is supported on 2 baffle plates. Each rear silencer has a welded hanger bar which supports the rear silencer on mounting rubbers. The outlet pipe is fitted with a welded twin outlet which is covered with 2 polished stainless steel finishers which are part welded to the silencer.

### Semi-Active Muffler Valve



NOTE: [LH\\_silencer](#) shown, RH (right-hand) silencer similar

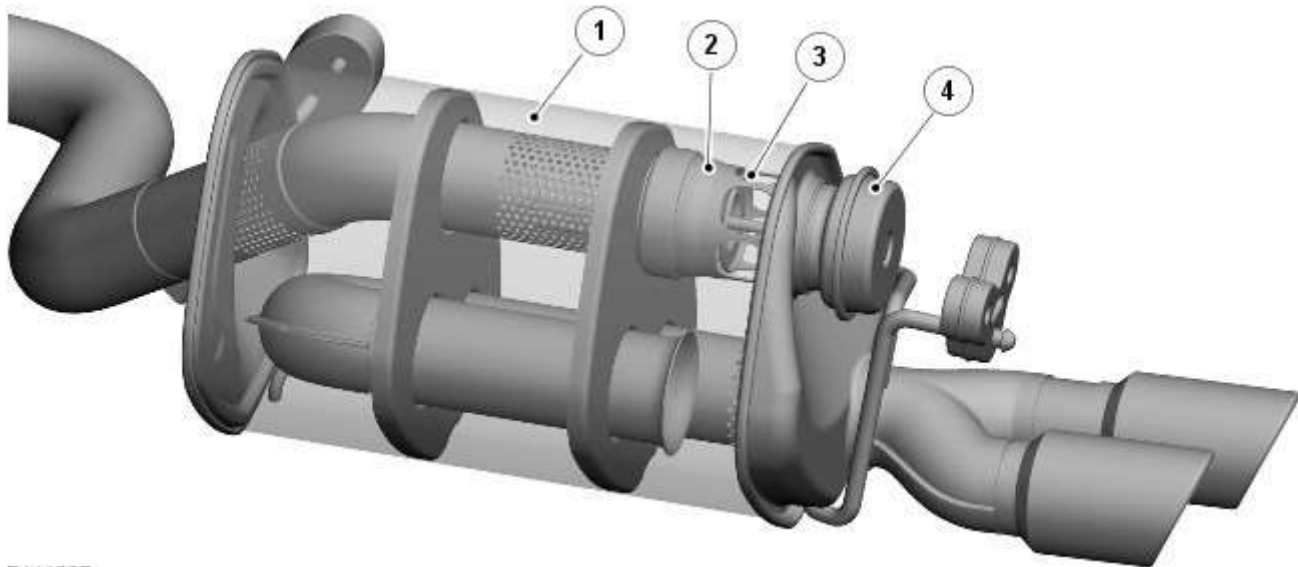

E114237

Item	Description
1	Outer case
2	Overpipe
3	Valve cage
4	Semi-active muffler valve assembly

A semi-active muffler valve is located in the rear of each rear silencer. The valve comprises a valve head, a valve shaft, a shaft guide, a housing shell, a membrane and a spring. The valve head is connected to the membrane by the valve shaft which is located within the shaft guide. The valve shaft is attached to the membrane with a pin. The membrane is located inside the housing shell and is held in position by the spring.

The valve head is located in and seals against the over pipe. When the exhaust gas pressure increases and overcomes the spring pressure, the valve head is lifted and the gasses by-pass the valve and are expelled through slots in the valve cage into the rear chamber and into the outlet pipe.

When the semi-active muffler valve is closed the exhaust gasses are expelled from the inlet tube through the perforations. The exhaust gasses then pass through perforations in the outlet pipe and are expelled from the silencer via the single outlet pipe and 2 polished stainless steel finishers.

When the semi-active muffler valve is open, the exhaust gasses are released into the rear chamber. The exhaust gasses then pass directly into the open end of the outlet pipe and are expelled from the silencer via the outlet pipe and the 2 polished stainless steel finishers. With the valve open, the gasses reduce through the baffle plates and tube perforations giving the exhaust note a more 'sporty' sound.

# Exhaust System - V8 5.0L Petrol/V8 S/C 5.0L Petrol - Exhaust System

Diagnosis and Testing

## Principle of Operation

For a detailed description of the exhaust system, refer to the relevant Description and Operation section of the workshop manual. REFER to: (309-00C Exhaust System - V8 5.0L Petrol/V8 S/C 5.0L Petrol)

[Exhaust System](#) (Description and Operation),

[Exhaust System](#) (Description and Operation),

[Exhaust System](#) (Description and Operation).

## Inspection and Verification



**CAUTION:** Diagnosis by substitution from a donor vehicle is **NOT** acceptable. Substitution of control modules does not guarantee confirmation of a fault and may also cause additional faults in the vehicle being checked and/or the donor vehicle.



**NOTE:** Check and rectify basic faults before beginning diagnostic routines involving pinpoint tests.

1. Verify the customer concern.
2. Visually inspect for obvious signs of damage and system integrity.

### Visual Inspection

<b>Mechanical</b>
<ul style="list-style-type: none"> <li>• Leaks</li> <li>• Metal fatigue</li> <li>• Pipes</li> <li>• Catalytic converter</li> <li>• Muffler(s)</li> <li>• Joints</li> <li>• Mountings</li> <li>• Clearance around components</li> </ul>

3. If an obvious cause for an observed or reported concern is found, correct the cause (if possible) before proceeding to the next step.
4. If the cause is not visually evident, verify the symptom and refer to the Symptom Chart, alternatively check for Diagnostic Trouble Codes (DTCs) and refer to the DTC Index.

## Symptom Chart

<b>Symptom</b>	<b>Possible Causes</b>	<b>Action</b>
Excessively noisy/leaking exhaust	<ul style="list-style-type: none"> <li>• Exhaust system/components</li> </ul>	Inspect exhaust system. Rectify leaks and install new components as required. Refer to Removal and Installation instructions in this section
Loss of power	<ul style="list-style-type: none"> <li>• Restricted exhaust system</li> <li>• Exhaust sound enhancement valve stuck closed</li> <li>• Fuel system</li> <li>• Ignition system</li> <li>• Electronic engine control</li> </ul>	Inspect exhaust system. Install new exhaust components as required. Refer to Removal and Installation instructions in this section. Check for fuel, ignition and electronic engine control system DTCs and refer to the relevant DTC Index

## DTC Index

For a list of Diagnostic Trouble Codes (DTCs) that could be logged in the Engine Control Module (ECM), please refer to Section 303-14. REFER to:

[Electronic Engine Controls](#) (303-14C Electronic Engine Controls - V8 5.0L Petrol, Diagnosis and Testing),

[Electronic Engine Controls](#) (303-14D Electronic Engine Controls - V8 S/C 5.0L Petrol, Diagnosis and Testing).

# Exhaust System - V8 5.0L Petrol/V8 S/C 5.0L Petrol - Catalytic Converter LH

Removal and Installation

## Removal



NOTE: Removal steps in this procedure may contain installation details.

1. Refer to: [Battery Disconnect and Connect](#) (414-01 Battery, Mounting and Cables, General Procedures).

2. WARNINGS:



Make sure to support the vehicle with axle stands.



Observe due care when working near a hot exhaust system.

Raise and support the vehicle.

3. Refer to: [Air Deflector](#) (501-02 Front End Body Panels, Removal and Installation).

4. Refer to: [Engine Rear Undershield](#) (501-02 Front End Body Panels, Removal and Installation).



5. CAUTION: Make sure the catalyst monitor sensor wiring harness is not twisted more than 180 degrees and is not in contact with either the exhaust or driveshaft.

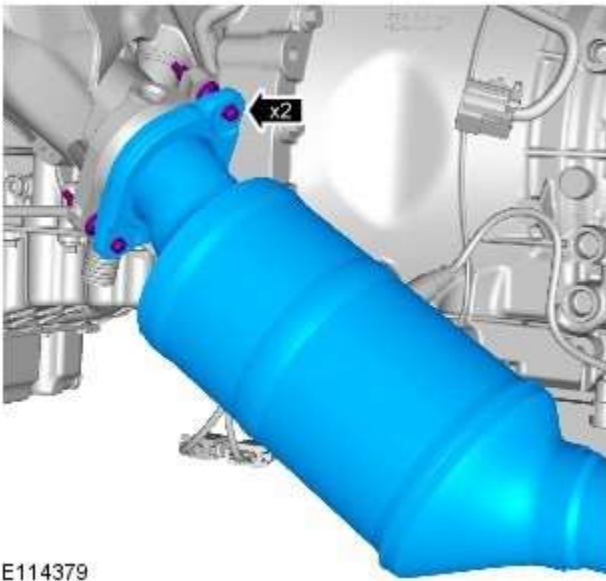

E114379



6. CAUTION: Make sure that the exhaust system is supported with suitable retaining straps.
- Tighten the top retaining nut first.
  - **Torque:**  
 Top nut 40 Nm  
 Bottom nut 40 Nm

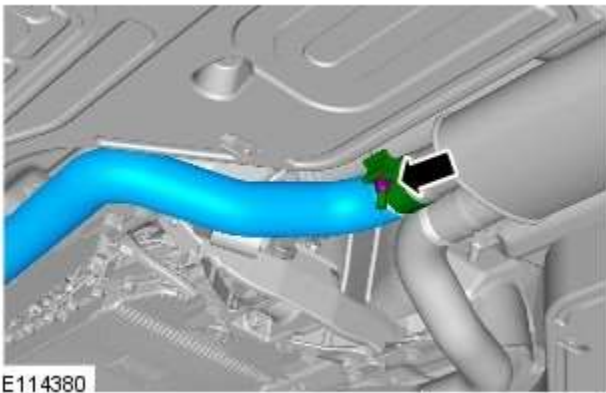

E114380



7. CAUTION: Make sure that the exhaust system is supported with suitable retaining straps.
- Torque:** 55 Nm

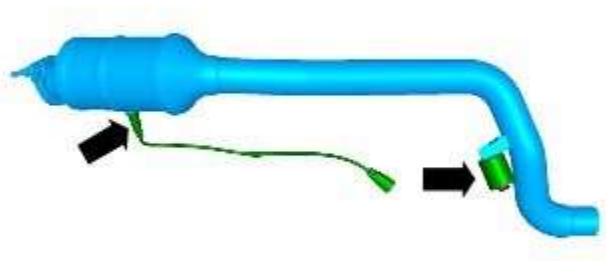

E114381

8. CAUTIONS:



Make sure the anti-seize compound does not contact the catalyst monitor sensor tip.



If accidentally dropped or knocked install a new sensor.

NOTES:



Do not disassemble further if the component is removed for access only.



If the original sensor is to be installed, apply lubricant meeting specification ESE-M12A4-A to the thread of the sensor.

**Torque:** 48 Nm

## Installation

1. To install, reverse the removal procedure.



2.  NOTE: For NAS vehicles only.

If required, carry out a long drive cycle.

Refer to: [Powertrain Control Module \(PCM\) Long Drive Cycle Self-Test](#)  
(303-14D Electronic Engine Controls - V8 S/C 5.0L Petrol, General Procedures).

# Exhaust System - V8 5.0L Petrol/V8 S/C 5.0L Petrol - Catalytic Converter RH

Removal and Installation

## Removal



NOTE: Removal steps in this procedure may contain installation details.

1. Refer to: [Battery Disconnect and Connect](#) (414-01 Battery, Mounting and Cables, General Procedures).

2. WARNINGS:



Make sure to support the vehicle with axle stands.



Observe due care when working near a hot exhaust system.

Raise and support the vehicle.

3. Refer to: [Air Deflector](#) (501-02 Front End Body Panels, Removal and Installation).

4. Refer to: [Engine Rear Undershield](#) (501-02 Front End Body Panels, Removal and Installation).

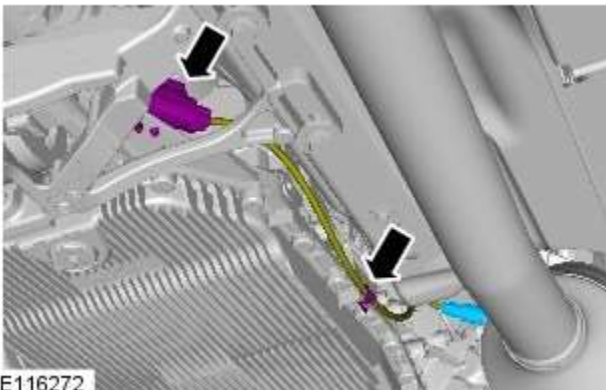

5. CAUTION: Make sure the catalyst monitor sensor wiring harness is not twisted more than 180 degrees and is not in contact with either the exhaust or driveshaft.

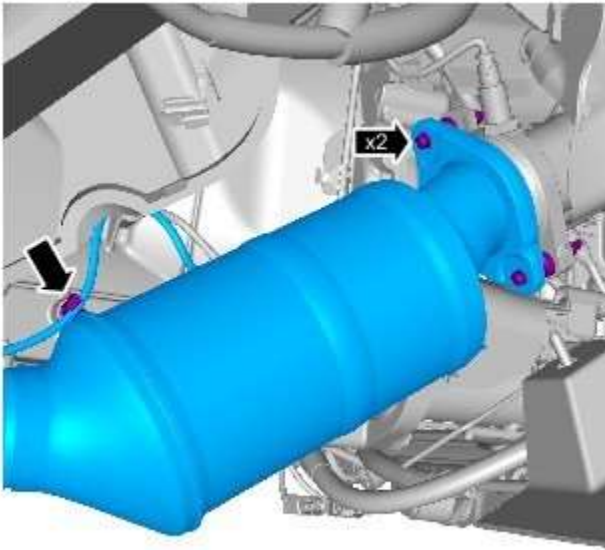

E116260



6. CAUTION: Make sure that the exhaust system is supported with suitable retaining straps.
  - Tighten the top retaining nut first.
  - **Torque:**
    - Top nut 40 Nm
    - Bottom nut 40 Nm

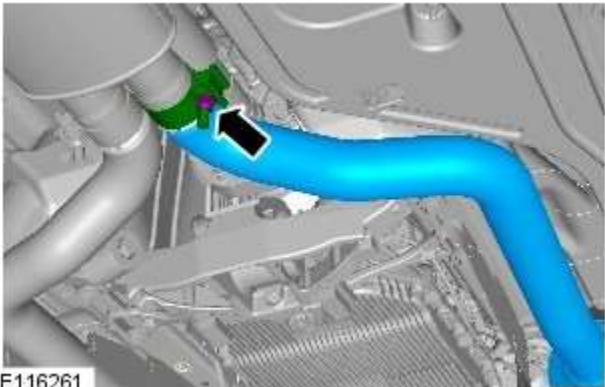

E116261



7. CAUTION: Make sure that the exhaust system is supported with suitable retaining straps.
 

**Torque:** 55 Nm

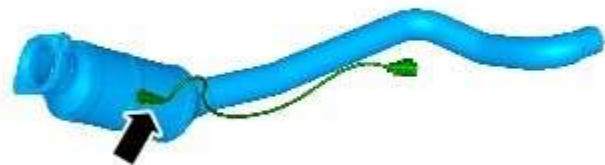

E116262

8. CAUTIONS:



Make sure the anti-seize compound does not contact the catalyst monitor sensor tip.



If accidentally dropped or knocked install a new sensor.

NOTES:



Do not disassemble further if the component is removed for access only.



If the original sensor is to be installed, apply lubricant meeting specification ESE-M12A4-A to the thread of the sensor.

**Torque:** 48 Nm

## Installation

1. To install, reverse the removal procedure.

2.  NOTE: For NAS vehicles only.

If required, carry out a long drive cycle.

Refer to: [Powertrain Control Module \(PCM\) Long Drive Cycle Self-Test](#)  
(303-14D Electronic Engine Controls - V8 S/C 5.0L Petrol, General Procedures).

# Exhaust System - V8 5.0L Petrol/V8 S/C 5.0L Petrol - Exhaust Sound Enhancement Valve

Removal and Installation

## Removal



**WARNING:** Observe due care when working near a hot exhaust system.

NOTES:



The exhaust sound enhancement valve is an integral part of the muffler and cannot be serviced separately.



Removal steps in this procedure may contain installation details.



- WARNING:** Make sure to support the vehicle with axle stands.  
Raise and support the vehicle.



- CAUTION:** Make sure that these components are installed to the noted removal position.

**Torque:**

M8 25 Nm

M10 55 Nm

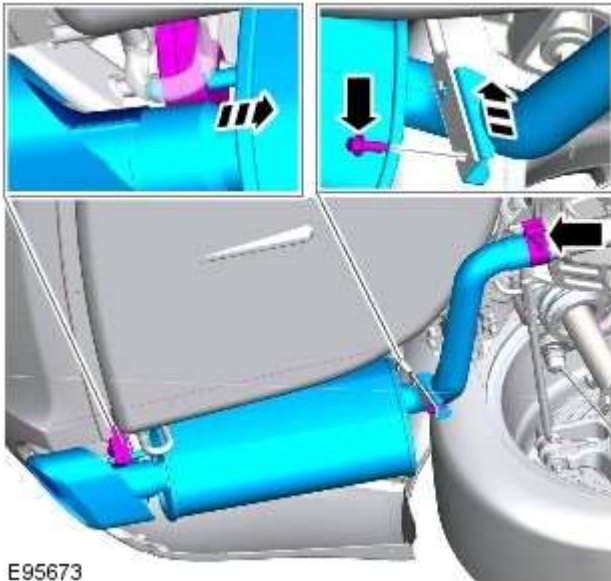

E95673

## Installation

- To install, reverse the removal procedure.

# Exhaust System - V8 5.0L Petrol/V8 S/C 5.0L Petrol - Exhaust System

Removal and Installation

## Removal



NOTE: Removal steps in this procedure may contain installation details.

1. Refer to: [Battery Disconnect and Connect](#) (414-01 Battery, Mounting and Cables, General Procedures).

2. WARNINGS:



Make sure to support the vehicle with axle stands.



Observe due care when working near a hot exhaust system.

Raise and support the vehicle.

3. Refer to: [Air Deflector](#) (501-02 Front End Body Panels, Removal and Installation).

4. Refer to: [Engine Rear Undershield](#) (501-02 Front End Body Panels, Removal and Installation).

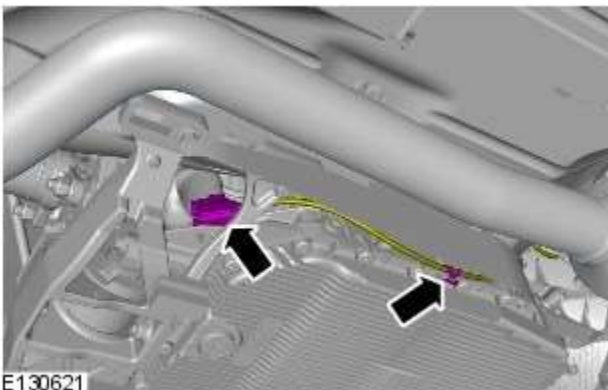

- 5.

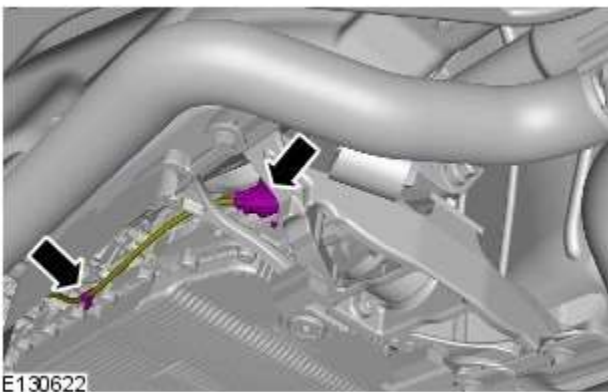

- 6.

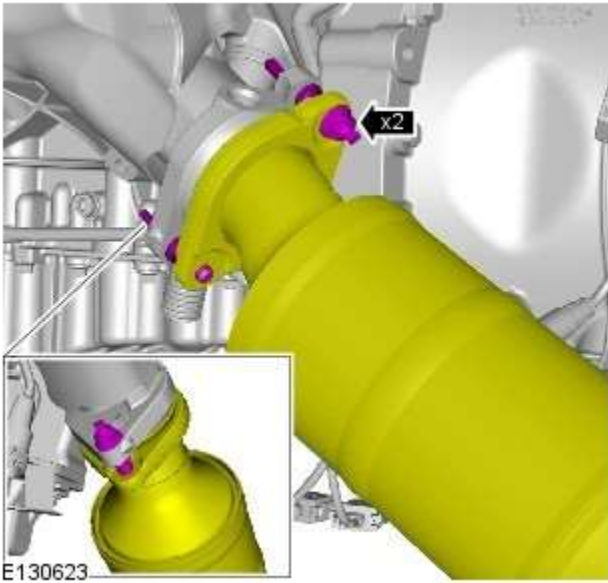

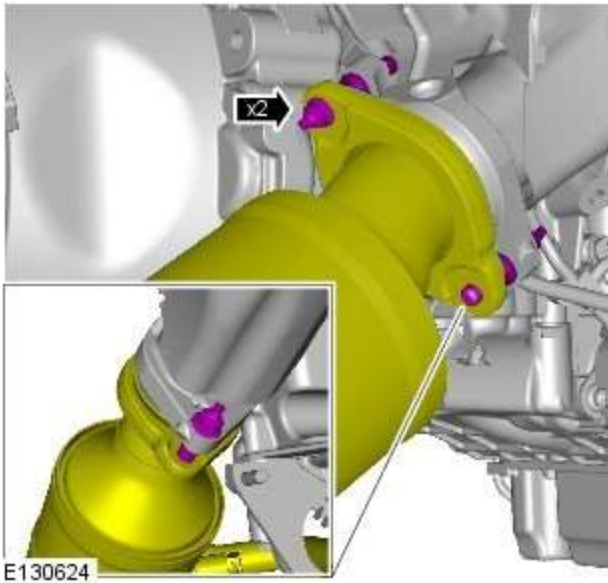

7. CAUTION: Make sure that the exhaust system is supported with suitable retaining straps.

*Torque:* 40 Nm

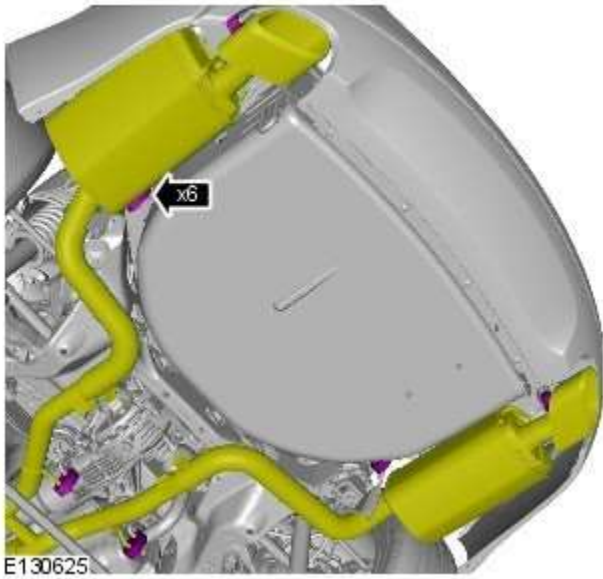

8. *Torque:* 40 Nm



9.  CAUTION: Make sure that the exhaust system is supported with suitable retaining straps.

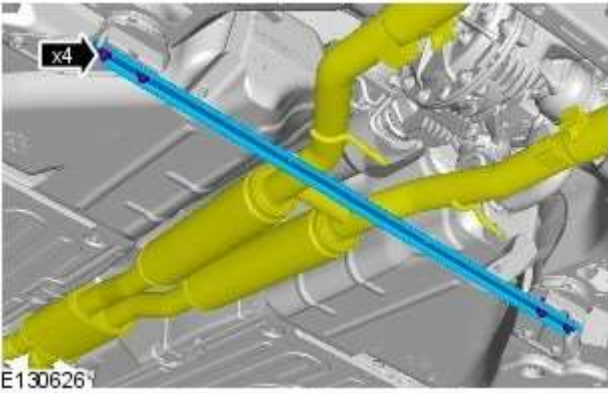

10.  CAUTION: Make sure that the exhaust system is supported with suitable retaining straps.  
*Torque: 30 Nm*

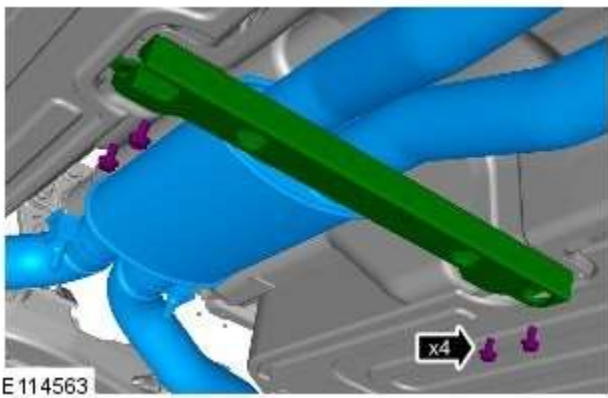

11.  CAUTION: Make sure that the exhaust system is supported with suitable retaining straps.  
*Torque: 6 Nm*



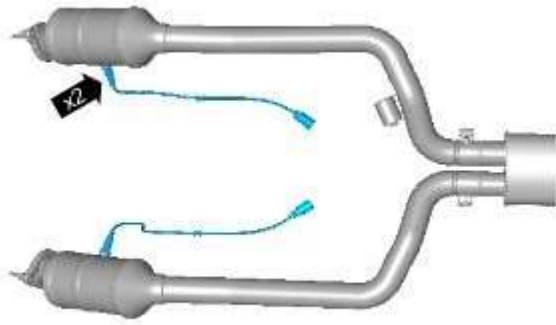

E 114565

12.  NOTE: Do not disassemble further if the component is removed for access only.

*Torque:* 48 Nm

## Installation

1. To install, reverse the removal procedure.

# Exhaust System - V8 5.0L Petrol/V8 S/C 5.0L Petrol - Front Muffler

Removal and Installation

## Removal



NOTE: Removal steps in this procedure may contain installation details.

### 1. WARNINGS:



Make sure to support the vehicle with axle stands.



Observe due care when working near a hot exhaust system.

Raise and support the vehicle.

### 2. Refer to: [Engine Rear Undershield](#) (501-02 Front End Body Panels, Removal and Installation).

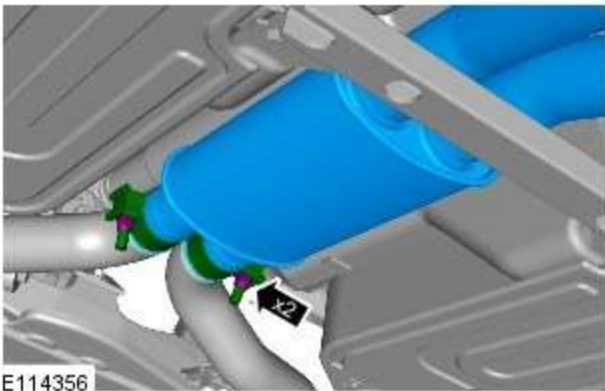

### 3. *Torque:* 55 Nm

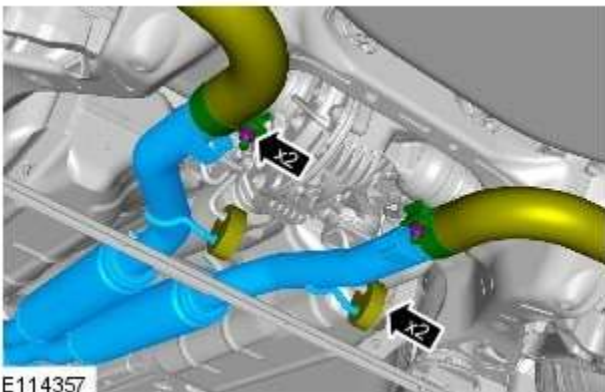

### 4. *Torque:* 55 Nm

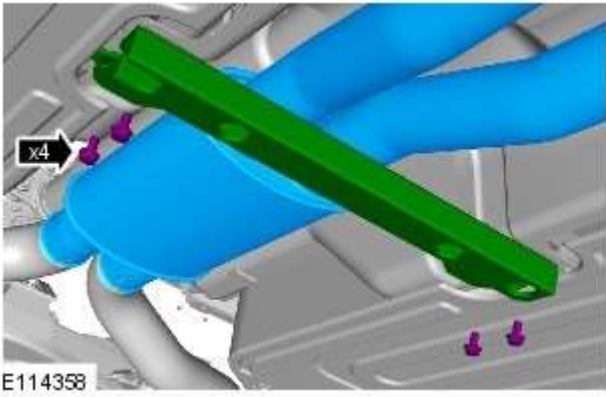

5.  CAUTION: Make sure that the exhaust system is supported with suitable retaining straps.

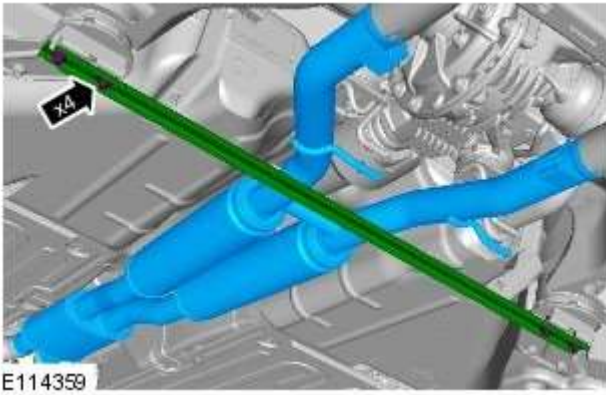

6.  CAUTION: Make sure that the exhaust system is supported with suitable retaining straps.

## Installation

1. To install, reverse the removal procedure.

## Exhaust System - V8 5.0L Petrol/V8 S/C 5.0L Petrol - Rear Muffler

Removal and Installation

### Removal



**WARNING:** Observe due care when working near a hot exhaust system.



**NOTE:** Removal steps in this procedure may contain installation details.

1.  **WARNING:** Make sure to support the vehicle with axle stands.  
Raise and support the vehicle.

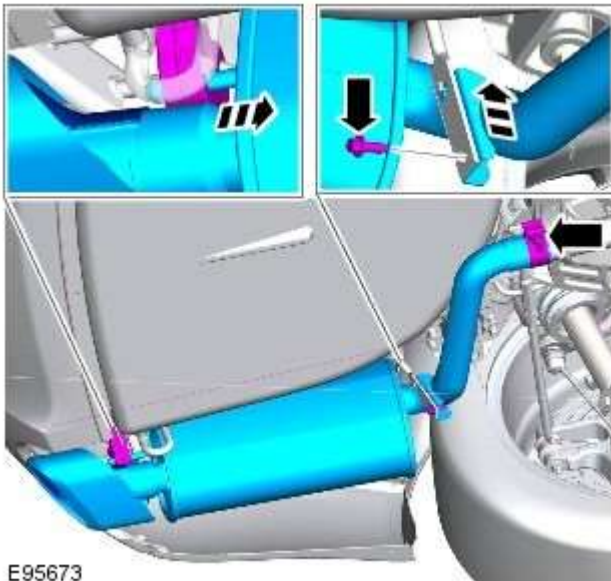

2.  **CAUTION:** Make sure that these components are installed to the noted removal position.

**Torque:**

M8 25 Nm  
M10 55 Nm

### Installation

1. To install, reverse the removal procedure.