

Monostrut Bushing Replacement Tool – Special Tool 204-201

MODEL
1997 MY-ON XK8 Range
1998 MY-ON V8 XJ Series

VIN
001001-ON
812256-ON

Issue:

Special Tool 204-201, Monostrut Bushing Replacer, (Illustration 1) has been introduced. The tool has a projecting mandrel to guide the new bushing and a step in the face to act as a distance control when the bushing is finally positioned in the monostrut. This bulletin describes the use of the tool.

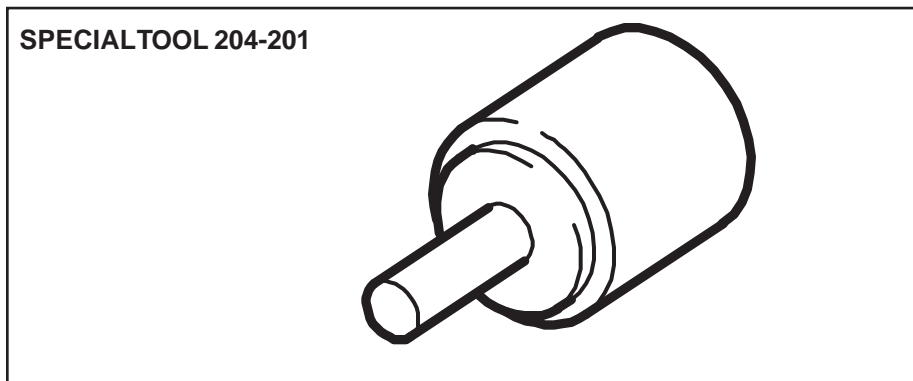

ILLUSTRATION 1

Action:INSTALLING MONOSTRUT BUSHING USING TOOL 204-201

1. Place the monostrut on a press bench, as shown in Illustration 2.
2. Lubricate the new bushing and place it on the tool mandrel and then place the tool and bushing in position on the bushing housing.
3. Ensure that the tool, bushing and mandrel are aligned, lower the press arbor to contact the tool and then apply pressure to fully insert the bushing.

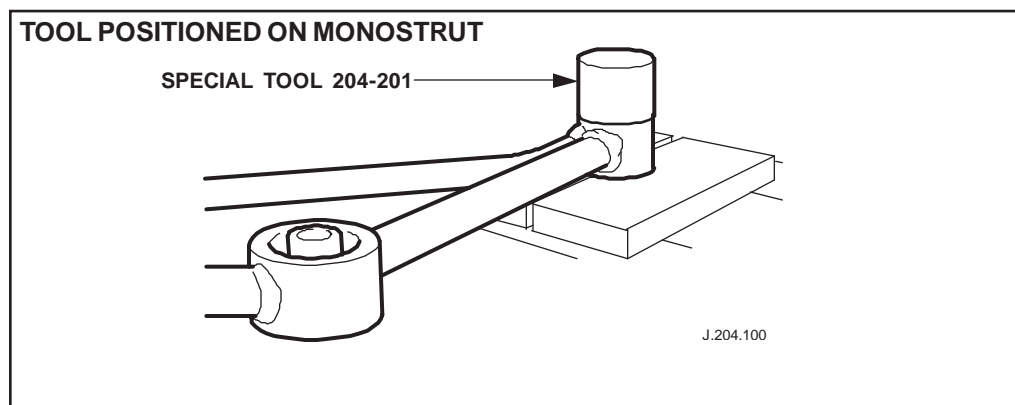

ILLUSTRATION 2