

Oil Leak – Pinion Oil Seal – Replace Pinion Drive Flange/Oil Seal Assembly – Procedure Not In Workshop Manual

MODEL
 1997 MY-ON XK8 Range
 1998 MY-ON V8 Sedan
VIN
 001001-ON
 812256-ON

Issue:

The differential pinion oil seal is manufactured as an assembly with the pinion drive flange and must be replaced as an assembly. This bulletin provides the procedure.

Action:

In case of a customer complaint of oil leakage which is found to be caused by oil leaking from the pinion oil seal, verify the complaint and perform the following action:

1. Raise the vehicle on a hoist and then support the rear of the vehicle on stands to allow rotation of the wheels.
2. Remove the front muffler and the driveshaft.

Note: Do not allow the driveshaft to hang from the transmission output shaft.

3. Rotate the pinion coupling until the machined slot in the threaded nose of the pinion, and the depressed area of the coupling retaining nut locking collar (A, Illustration 1), are accessible.

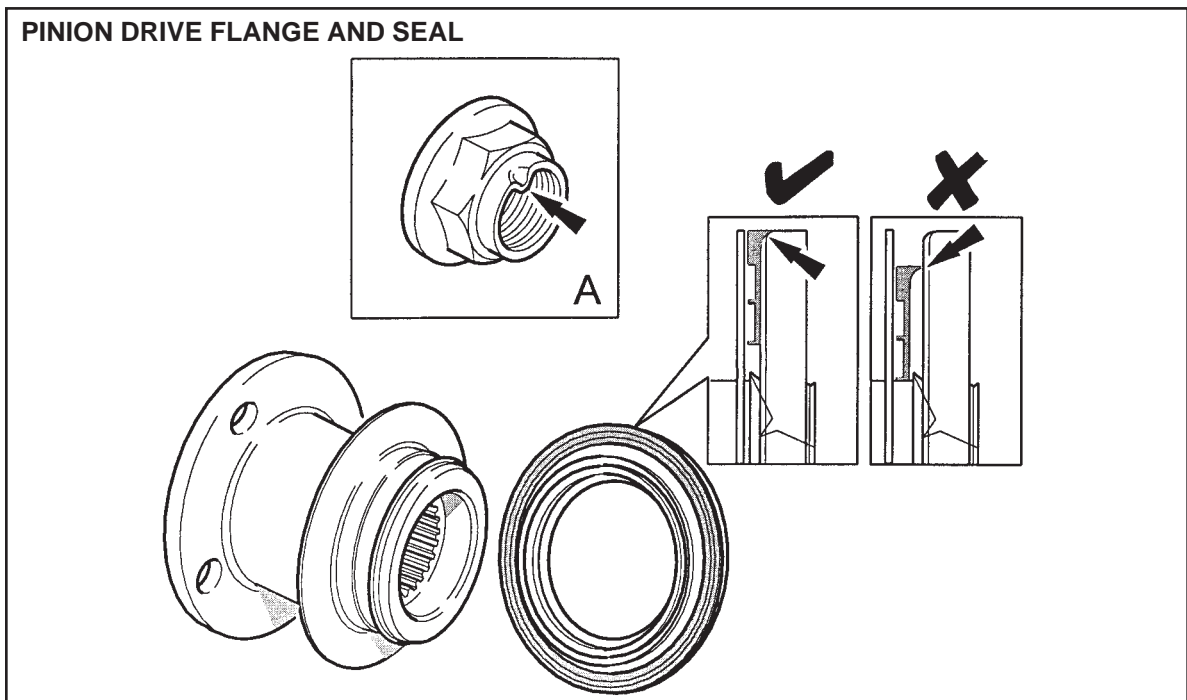

ILLUSTRATION 1

4. Using a punch, preferably with a square section nose to fit into the slot, drive the depressed part of the nut collar out of the slot.
5. Place Special Tool 205-053 (18G-1205), Drive Shaft Flange Wrench, on the coupling to prevent rotation and then, using a socket wrench, loosen and remove the coupling retaining nut.
6. Remove Special Tool 205-053 (18G-1205) from the coupling
7. Install Special Tool 100-005, puller, to the coupling, apply the center screw to the pinion nose and then rotate the screw to withdraw the coupling.
8. Remove the Special Tool and discard the coupling/seal assembly.
9. Clean the seal housing area in the differential case.
10. The coupling/seal assembly, shown in Illustration 1 consists of the following:
 - Coupling with integral seal sleeve.
 - Ryton ring
 - Oil seal

Note: In Illustration 1, the inset with the check mark shows the proper location of the Ryton ring between the seal and the seal flange. The Ryton ring should be concentric with the seal and the lip on the ring should overlap the edge of the seal. The inset with the X shows the incorrect location of the Ryton ring, i.e. not concentric with the seal and resting on the integral seal sleeve. The Ryton ring **MUST** be handled carefully, as it is easily damaged. If the ring is allowed to drop out of position it can be broken when the seal is inserted into the housing.

11. Lightly lubricate the circumference of the seal.
12. Place the coupling on the pinion shaft splines and slide it into position until the seal is adjacent to the housing.
13. At this point check that the Ryton ring is in the proper location.
14. Position the 205-053 (18G-1205) wrench, on the coupling to prevent rotation and then, using a socket wrench, lightly tighten the nut until the seal begins to enter the housing.
15. Before proceeding check that the Ryton ring is still in position against the seal and not protruding.
16. Tighten the nut, against the wrench, to the torque setting of 203 - 223 Nm (150-164 lb ft).
17. Remove the wrench from the coupling.
18. Check the oil level at the filler/inspection plug in the rear cover of the differential unit and if the oil level is below the orifice, add oil, as listed under Parts Information, until the level reaches the lower edge of the orifice.

Parts Information:

<u>DESCRIPTION</u>	<u>PART NUMBER</u>	<u>QTY</u>
Pinion oil seal service kit XK8	JLM 20601	1
Pinion oil seal service kit XJ8	JLM 20602	1
Shell thermally-stable Spirax 90	JLM 20255	A/R

Warranty Information:

<u>FAULT CODE</u>	<u>R.O. NUMBER</u>	<u>DESCRIPTION</u>	<u>TIME ALLOWANCE</u>
FV CF HJ	51.20.01	Replace pinion oil seal	1.30 hrs.
	10.10.10	Drive in/drive out	0.15 hrs.