

**Steering Rack – Leak at Transfer Pipe
Union Nut – Replace O-rings**MODEL 1997 MY-ON
XK8 Range
VIN
001001-ON**Issue:**

The steering rack of some 1997 MY-ON XK8 vehicles may leak at one of the transfer pipe union nuts. The cause of the leak is damage to the O-ring seal beneath the union nut caused during installation. Before replacing the entire steering rack, the O-ring (Illustration 1) should be replaced and the system tested.

Action:

When diagnosing a customer complaint of power steering rack leakage on a 1997 MY-ON XK8, proceed as follows:

REPLACING TRANSFER PIPE O-RINGS

1. Open the hood and install fender covers.
2. Raise the vehicle on a suitable hoist.
3. Center the steering wheel and remove the ignition key.

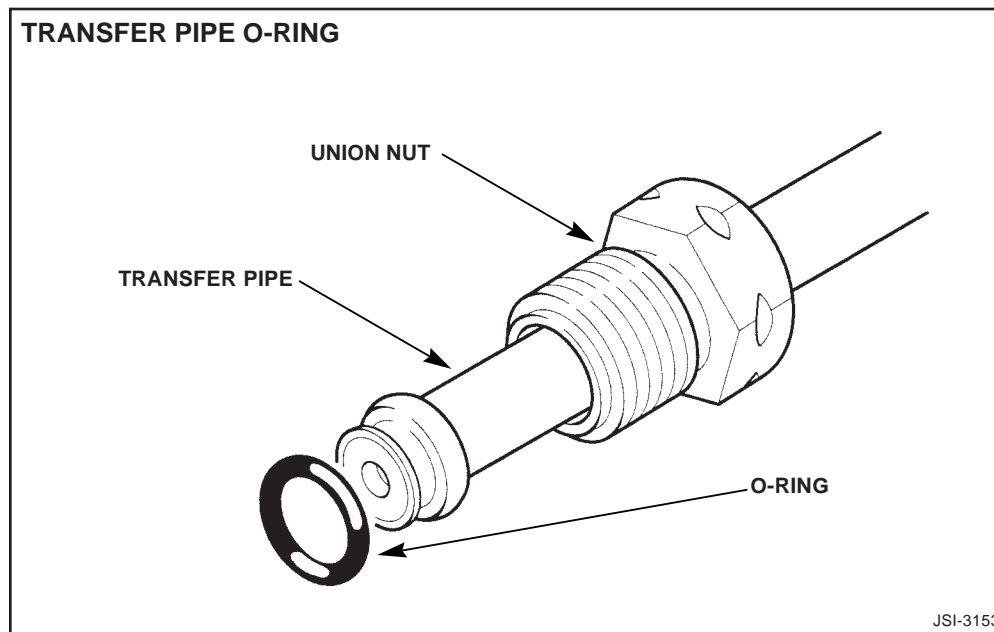

ILLUSTRATION 1

- Align the pinion centering cap with the lug on the pinion housing (Illustration 2) to precisely center the rack.

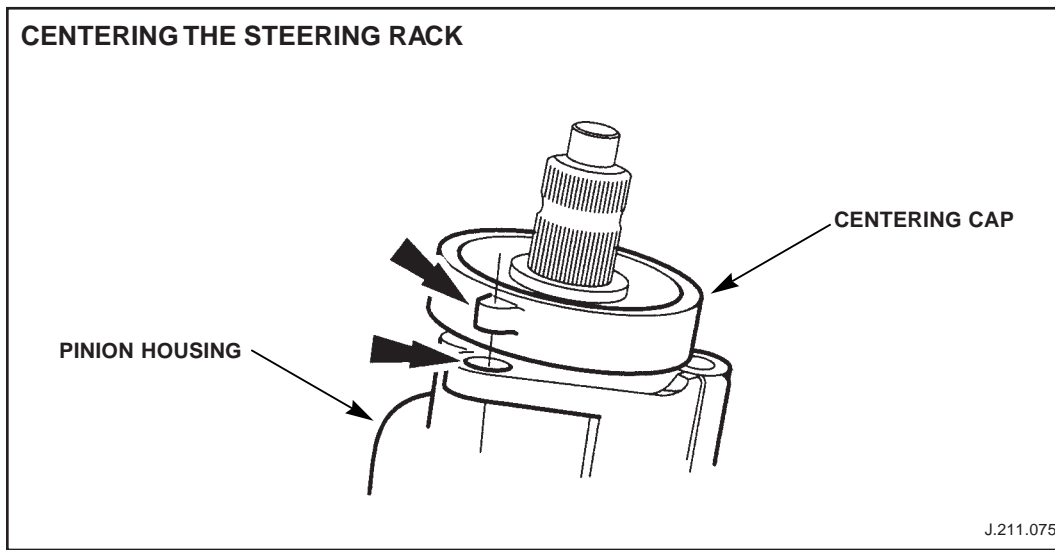

ILLUSTRATION 2

- Loosen and remove the lower column clamp bolt at the pinion coupling.
- Disconnect the steering column from the pinion and then move the column upwards.
- Disconnect the transducer multi-plug.
- Remove the tie straps that secure the return hose and the transducer harness to the rack.
- Remove the feed hose insulation sleeves.
- Thoroughly clean the rack around the areas of the feed and return unions and the transfer pipes.
- Place a drain tray under the area of the pinion housing.
- Remove the bolt from the plate that retains the feed and return unions in the pinion housing and then remove them from the housing.
- Allow the fluid to drain into the tray.
- Remove the O-rings from the threaded ports in the pinion housing where the feed and return pipes were installed.
- Remove the steering rack mounting bolts and lower the rack.
- Loosen the transfer pipe union nuts, in both the rack and the pinion housings, and then remove the pipes from the rack.
- Remove the O-rings from the threaded ports, in both the rack and the pinion housings, where the transfer pipes were installed.
- Discard the O-rings that were removed.
- Thoroughly clean the areas around the threaded ports, lubricate the replacement O-rings and then install them to the transfer pipes.
- Install the transfer pipes on the rack assembly, using care not to damage the O-rings against the thread in the port.

21. Thread the union nuts and lightly tighten them while checking that the pipes and the O-rings are properly seated in the bores.
22. Using a crowfoot wrench on a torque wrench, tighten the union nuts to 7 - 8 Nm (5.2 - 5.9 lb ft or 62 - 70.8 lb in).
23. Raise the rack into position on the crossmember, place the return hose behind the pipes and then install the retaining bolts.
24. Tighten the retaining bolts to 30 - 40 Nm (22.1 - 29.5 lb ft).
25. Thoroughly clean the areas around the threaded bores of the feed and return ports, lubricate the replacement O-rings and then install them to the feed and return pipes.
26. Install the feed and return pipes into the pinion housing, align the retaining bracket and then install and tighten the retaining bolt.
27. Clean the rack assembly of any spilled fluid.
28. Install the feed pipe insulation sleeves.

NOTE: Install new ratchet straps to retain the return hose and the transducer harness to the rack.

29. Reinstall the lower column to the pinion and then install and tighten the clamp bolt.
30. Reconnect the harness connector to the transducer.
31. Remove the drain tray and dispose of the fluid properly.
32. Lower the vehicle and refill the steering reservoir.
33. Start the engine and turn the steering lock to lock to purge any air from the system.
34. Check for fluid leaks at any of the pipe fittings.
35. Check that the steering wheel is centered.
36. Remove the fender covers and close the hood.

Parts Information:

<u>DESCRIPTION</u>	<u>PART NUMBER</u>	<u>QTY</u>
O-ring seal	JLM 11320	A/R

Warranty Information:

<u>FAULT CODE</u>	<u>R.O. NUMBER</u>	<u>DESCRIPTION</u>	<u>TIME ALLOWANCE</u>
GB BG HJ	57.10.33	PAS rack - replace transfer pipe O-rings	1.05 hrs.